



PPCC Manuals for: Installation, Maintenance, Safety, and Parts List

Recommended Spare Parts in Highlighted Print

Troughing Idler Incline Conveyor Manual

Serial # _____

Model # **IE** _____

Computer Code _____

SAFETY FIRST!



Failure to follow all safety stickers, placards and maintenance manual instructions may result in serious injury to operators or maintenance personnel.

NOTE:

Equipment may start automatically if a sensing device, such as a photo-eye or proximity switch, is accidentally blocked. Equipment may start automatically when a zone is placed in the "automatic" mode. Disable control system outputs before working on any automatic equipment.

FOLLOW YOUR SAFETY PROCEDURES AND INSTRUCTIONS FOR ALL OPERATOR AND MAINTENANCE PROCEDURES.

SOME SAFETY DO'S AND DON'TS:

- **DO NOT** enter areas designated "Authorized Personnel Only" or confined spaces without prior authorization and without following (L.O.T.O.) procedures.
- **DO NOT** operate any equipment without all factory-supplied guards securely installed in their proper locations.
- **DO NOT** bypass or defeat any safety device at any time.
- **DO NOT** reset any tripped EMERGENCY STOP button or cable without first determining the cause of the trip.
- **DO NOT** reach over, around, or through any guard or safety barrier without first following proper (L.O.T.O.) procedures.
- **DO NOT** clean or work under any lift table without using proper maintenance stops.
- **DO NOT** walk, sit, ride, or climb on conveyor at any time.
- **DO NOT** remove or alter conveyor guards of safety barriers.
- **DO NOT** load conveyor beyond design limits.
- **DO** follow plant Lock-Out, Tag-out (L.O.T.O.) procedures when working on machinery, including pneumatic devices.
- **DO** disable the control circuit output before working on any conveyor.
- **DO** lock-out the main and any auxiliary control panels before working on any conveyor.
- **DO** be aware that hazardous voltages may still be present in control cabinets even if the disconnect is locked out.
- **DO** lock-out the air supply to all equipment before working on or around any pneumatic device.
- **DO** verify that the energy source to the equipment is off before beginning any work.
- **DO** keep clothing, hair, fingers, and other body parts away from conveyor at all times.
- **DO** use all required personal protective equipment at all times when working on equipment.
- **DO** allow only authorized maintenance personnel to service conveyor.
- **DO** know the location and function of all start/stop controls.
- **DO** keep all start/stop controls free of obstruction.
- **DO** keep all personnel clear of conveyor when starting.
- **DO** operate conveyor with trained personnel only.
- **DO** verify that all personnel are clear of conveyor before switching into automatic mode.

*****POWER-PACK CONVEYOR COMPANY*****
*****IF IT'S NOT SAFE, DON'T DO IT*****

Table of Contents



Introduction:	Page	Maintenance:	Page
Caution Stickers.....	2	Remove, Shorten & Relace Belt.....	9
Receiving Instructions.....	3	Reducer, Bearing, Chain & Motor.....	10
Approval Drawing and BOM.....	3		
Installation:		Parts List & Spare Parts:	
Match Mark Numbers.....	3	Welded Conveyor.....	11
Floor Support Installation.....	4	How to Order Parts.....	12
Conveyor Setup.....	5	Additional Solutions.....	13
Conveyor Alignment.....	5	Notes.....	14-15
Belt Installation.....	6		
Operation:			
Drive Chain Alignment and Tension.....	6-7		
Belt Tracking Non-Reversing.....	7		
Belt Tracking Reversing.....	8		
Electrical Controls.....	8		
Start-Up.....	8		

Caution Sticker



Located on side of Conveyor



Located on side of Conveyor



Located on Guard

Continuing Engineering Advances may cause changes to information shown.

Power-Pack Conveyor Company

38363 Airport Parkway • Willoughby, OH 44094 • Phone: (440) 975-9955 • Fax: (440) 975-0505

Introduction



Receiving Instructions:

A. Check the number of crates, boxes, skids, etc. received against the Bill of Lading, to make sure all items shipped have been received. Check to see if any equipment was damaged in transit. If damages occurred, note damages on freight bill and immediately contact the motor carrier to a file claim for the damages.

Approval Drawings:

B. PPCC supplies approval drawings and a Bill of Material (BOM) on each conveyor to your engineering department for approval before fabrication. If you have a design or dimension question please refer to these drawings. For any additional assistance contact PPCC at (440) 975-9955 and ask for the Engineering Manager.

-

Installation

Match Mark Numbers

All body sections are match marked with letters and numbers as follows: A-1 to A-1 etc. at body splice. See figure 3A.

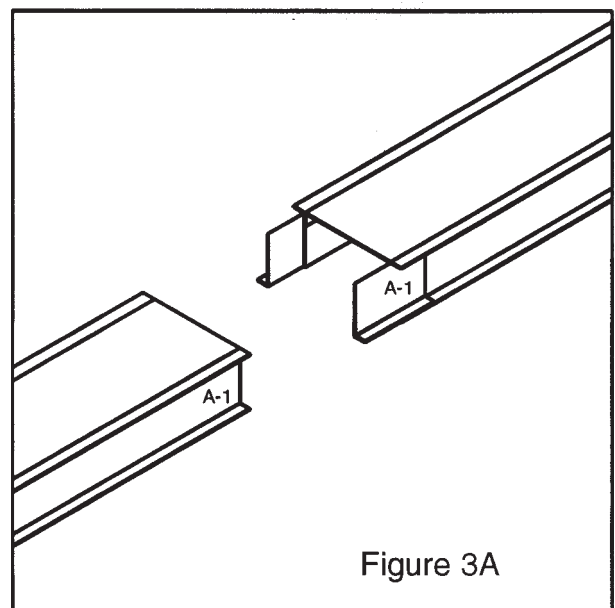

Figure 3A

Continuing Engineering Advances may cause changes to information shown.

Power-Pack Conveyor Company

38363 Airport Parkway • Willoughby, OH 44094 • Phone: (440) 975-9955 • Fax: (440) 975-0505

Conveyor Setup



Figure 4A

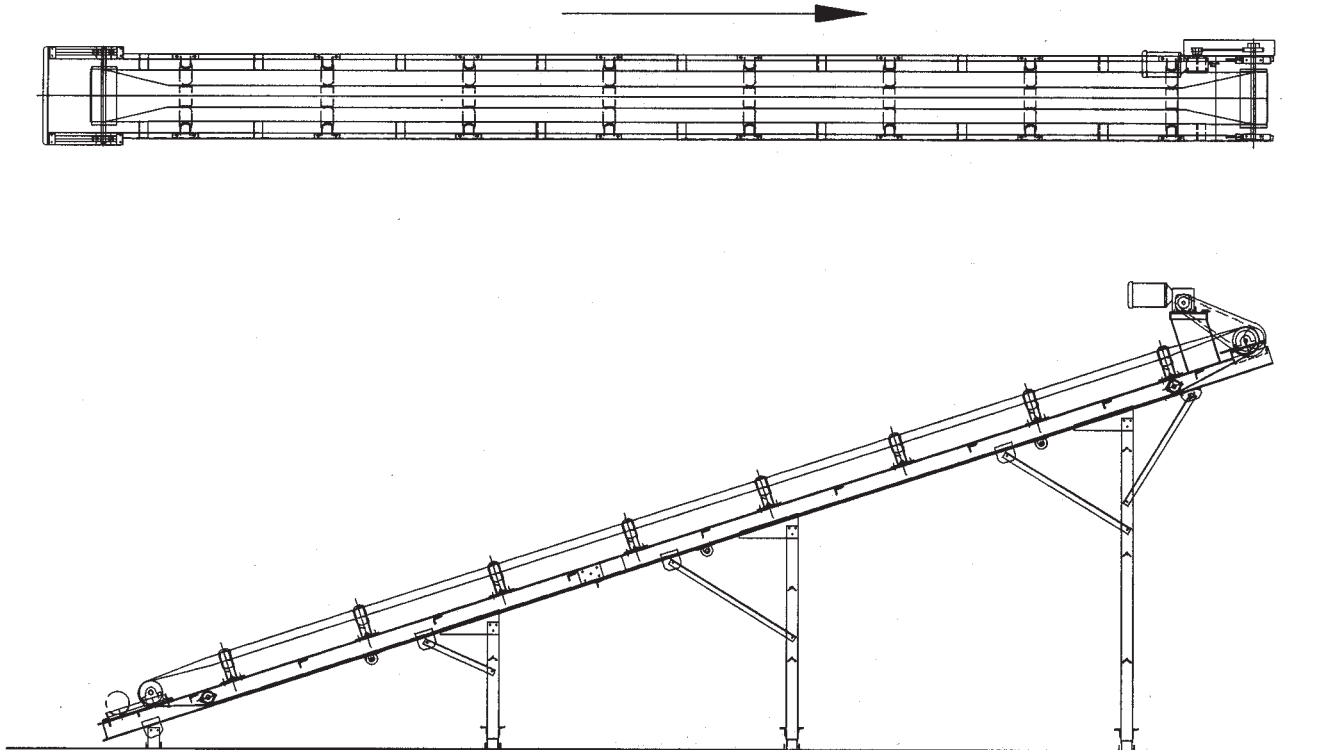

Level conveyor, adjust supports to required height and lag to floor.

Continuing Engineering Advances may cause changes to information shown.

Power-Pack Conveyor Company

38363 Airport Parkway • Willoughby, OH 44094 • Phone: (440) 975-9955 • Fax: (440) 975-0505

Belt Installation



Check to see if your conveyor belt has been pre laced at the factory. If not, install belt with bare back down and the shiny or covered side up.

Pull belt ends together and insert lacing pin. See figure 5A.

Belt tension should be taken up at the take-up end section. See figure 5A. Enough belt tension should be taken so the drive roll does not slip when carrying full loads. **DO NOT OVER TENSION.**

Keep the drive and take-up rolls parallel to the bed by moving both take-up bolts until roll is parallel. See figure 5A.

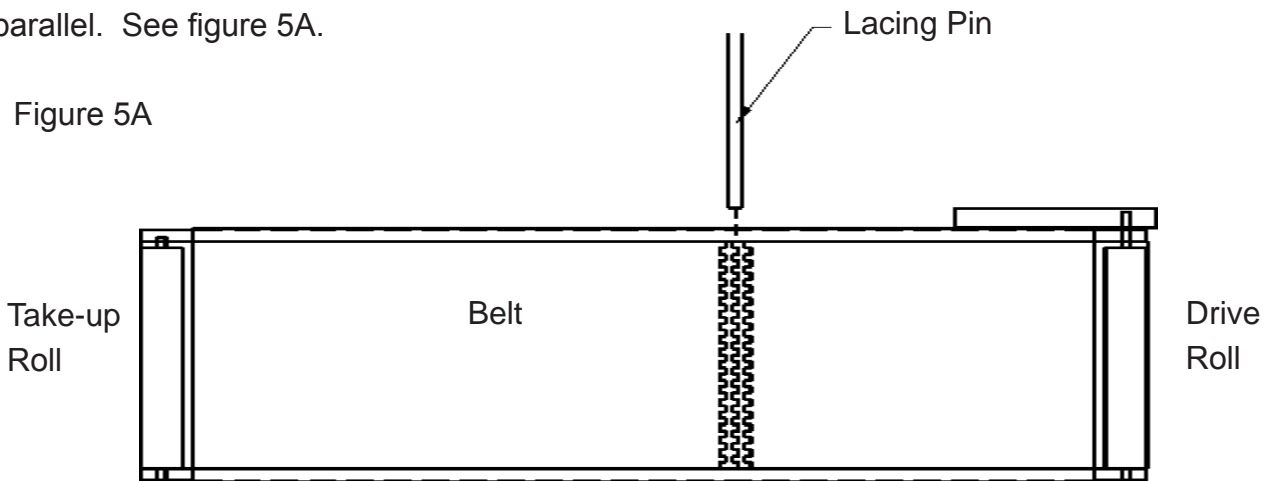
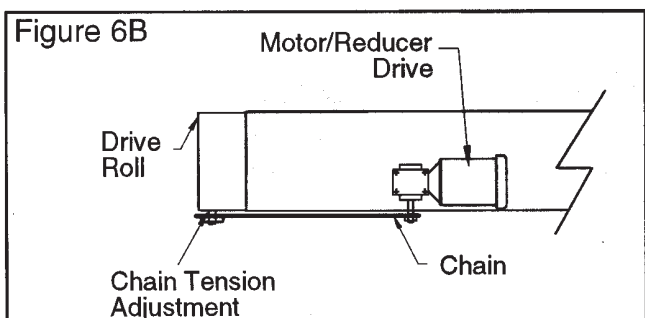
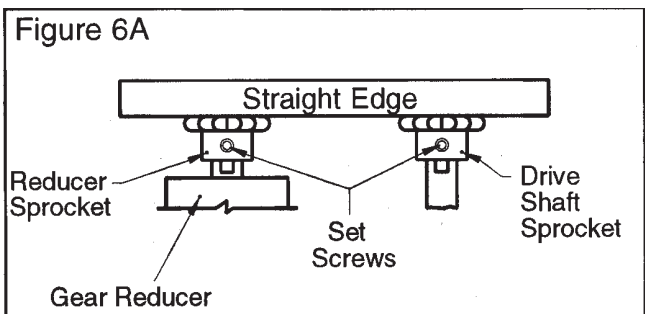

Figure 5A

Operations

Drive Chain Alignment & Tension

The drive chain and sprockets should be checked periodically for proper tension and alignment. Improper adjustment will cause premature wear to the drive components. See page 7 for proper chain tension instructions.



Continuing Engineering Advances may cause changes to information shown.

Power-Pack Conveyor Company

38363 Airport Parkway • Willoughby, OH 44094 • Phone: (440) 975-9955 • Fax: (440) 975-0505



TO MAKE ADJUSTMENTS

- 1... Remove chain guard.
- 2... Check sprocket alignment by placing a straight edge across the face of both sprockets (Figure 6A). Loosen set screws and adjust as needed. Retighten set screws.
- 3... To adjust chain tension, loosen bolts on motor base. Tighten until desired chain tension is reached (Figure 6C). Retighten mounting belt.
- 4... Lubricate chain per maintenance instructions.
- 5... Replace chain guard so that it does not interfere with drive.

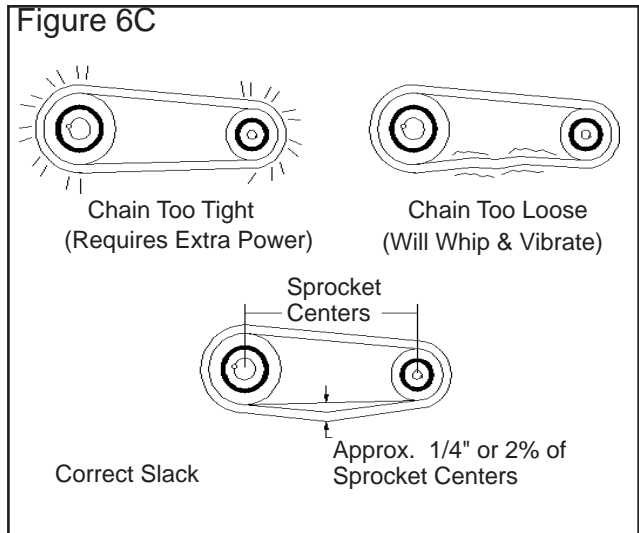

CAUTION!
NEVER REMOVE CHAIN GUARDS WHILE THE CONVEYOR IS OPERATING. ALWAYS REPLACE GUARDS AFTER ADJUSTMENTS ARE MADE.

Belt Tracking Non-Reversing

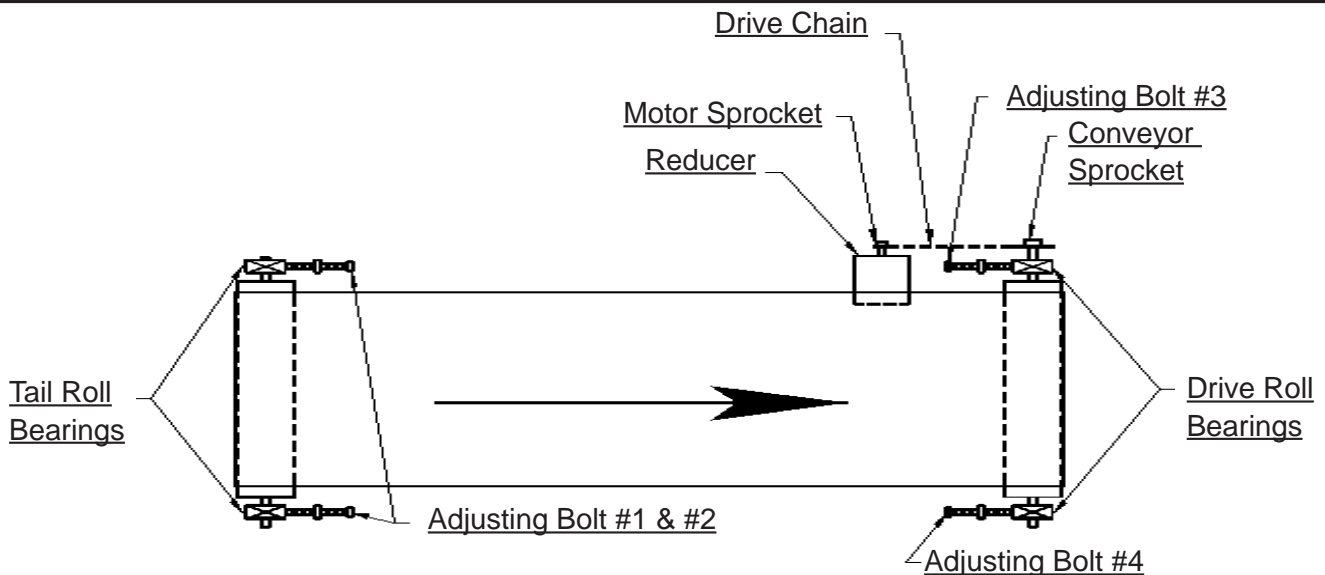

Belt Tension: Increase belt tension by taking an even number of turns on adjusting bolts #1 & #2 at end opposite drive. If belt tends to run to one side, adjust bolt on that side to re-center belt on roll.

Chain Tension: Remove chain guard. Turn adjusting bolt #3 to tighten drive chain. Replace guard. Run conveyor, center belt on roll by adjusting bolt #4.

WARNING- DO NOT RUN CONVEYOR WITH CHAIN GUARD DETACHED. CAUTION: OVERTIGHTEN DRIVE CHAIN WILL CAUSE EXCESSIVE WEAR ON DRIVE COMPONENTS

CAUTION: DO NOT RIDE, SIT, STAND OR WALK ON CONVEYOR AT ANYTIME.

Continuing Engineering Advances may cause changes to information shown.

Power-Pack Conveyor Company

38363 Airport Parkway • Willoughby, OH 44094 • Phone: (440) 975-9955 • Fax: (440) 975-0505

Electrical Controls



If controls are supplied with your equipment, see wiring diagram located in door of control panel.

Start-Up

Before conveyor is turned on, remove any foreign objects on conveyor belt. **After conveyor has been turned on, check your plant to conveyor motor amp draws to make sure your plant has sufficient power requirements.**

Continuing Engineering Advances may cause changes to information shown.

Power-Pack Conveyor Company

38363 Airport Parkway • Willoughby, OH 44094 • Phone: (440) 975-9955 • Fax: (440) 975-0505

Remove, Shorten or Relacing Belt

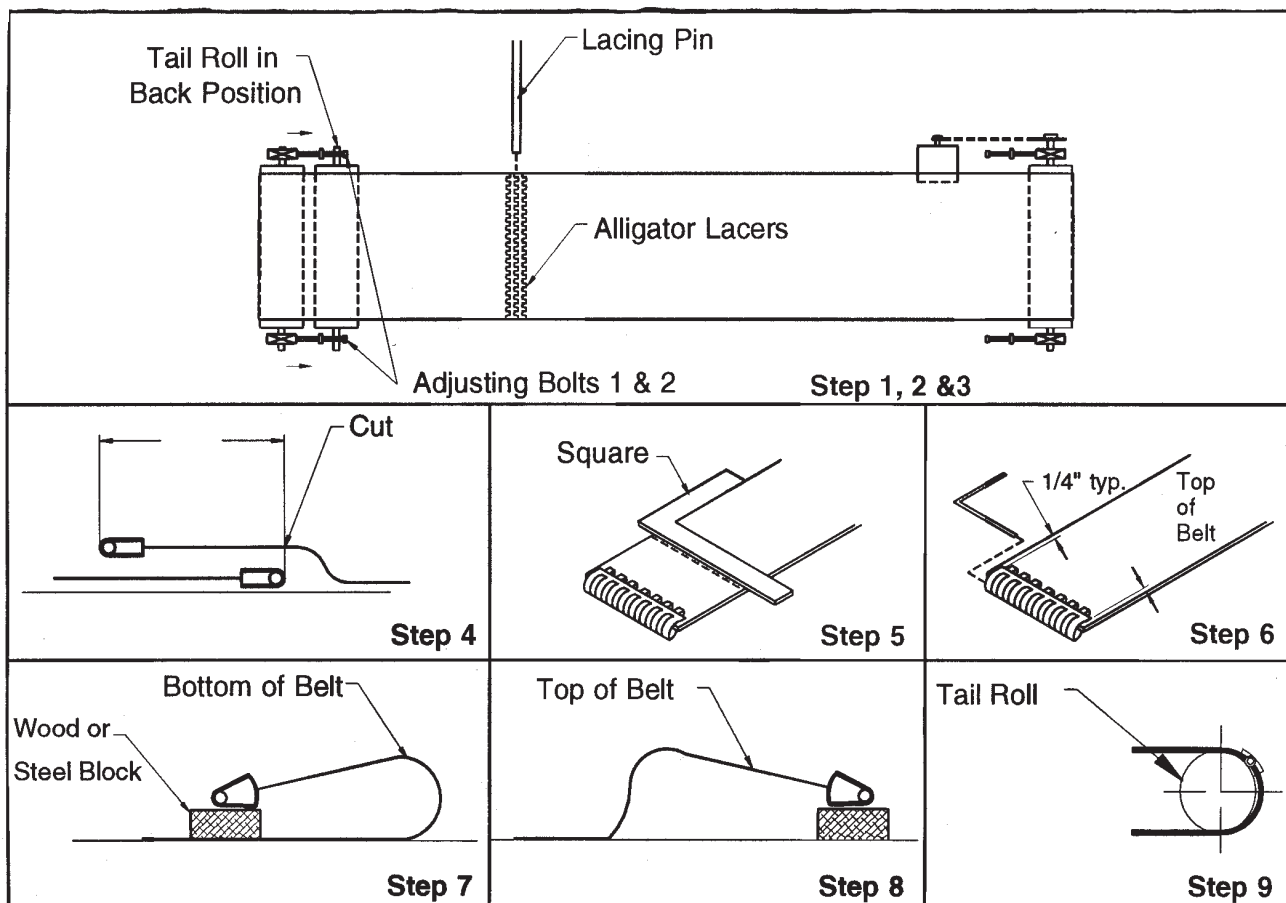

1. Run conveyor to bring lacers to the top of conveyor. **CAUTION! DISCONNECT POWER BEFORE MAKING REPAIRS ON CONVEYOR.**
2. Loosen adjusting bolts 1 & 2 at end opposite drive to bring tail roll in back position.
3. Pull lacing pin from belt.
4. Over lap belt ends to determine how much belt should be shortened & marked.
5. Lay square on belt and cut. It is important that the belt is cut square for proper tracking. (Note! Excessive belting may be cut off one end or equal amounts off each end. If you cut off one end, it is not necessary to replace lacer on other end of belt unless lacers are worn.)
6. Center Alligator lacing on belt, ribbed side up. Insert gauge pin between belt and lacers. Hammer tooth at each edge enough to hold lacing in place. When attaching second half of lacer, check that both ends mesh, with edges flush.
7. Fold belt back on block of wood. Hold lacing tight against end of belt, hammer teeth halfway into belt.
8. With top of belt up and lacing on block of wood, hammer teeth flush with belt - avoid hitting gauge pin or loops.
9. Attach belt to conveyor at foot roll with ribbed side of lacers up. Hammer lacers on tail roll until flush and lacers conform to curvature of roll.
10. Adjust tail end for proper belt tension and alignment, (see belt installation pg 5).

Continuing Engineering Advances may cause changes to information shown.

Power-Pack Conveyor Company

38363 Airport Parkway • Willoughby, OH 44094 • Phone: (440) 975-9955 • Fax: (440) 975-0505

Reducer, Bearing, Chain & Motor



Reducer:

Check reducer oil level periodically. See reducer manual for type of oil required.

Bearings:

Return idler bearings are either free running ball bearings and need no lubrication or they are cartridge style bearings pre-lubricated at the factory for the life of the bearing under normal operating conditions.

All pillow block and flanged bearings are pre-lubricated at the factory for operating life of the bearing under normal conditions. Grease fittings are also supplied on these bearings, so under extreme operating conditions bearings can be inspected and greased with a lithium base grease conforming to a NLGI grade 2 consistency, as required.

CAUTION: OVER GREASING WILL CAUSE GREASE SEAL TO BREAK AND BEARING MAY FREEZE-UP FROM LOSS OF GREASE.

Chain:

It is recommended that the drive chain be lubricated with SAE-30 oil approximately every 40 hours of operation. Under extreme conditions, more frequent lubrication may be required.

Motor:

See motor manual.

Continuing Engineering Advances may cause changes to information shown.

Power-Pack Conveyor Company
38363 Airport Parkway • Willoughby, OH 44094 • Phone: (440) 975-9955 • Fax: (440) 975-0505

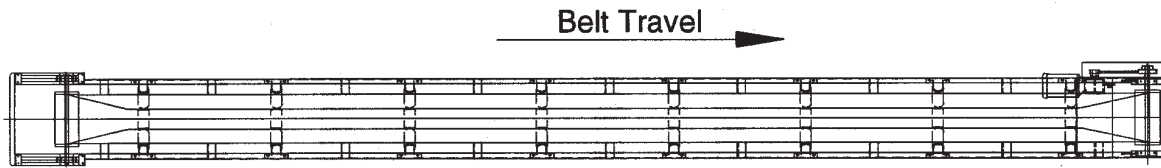

TOP VIEW

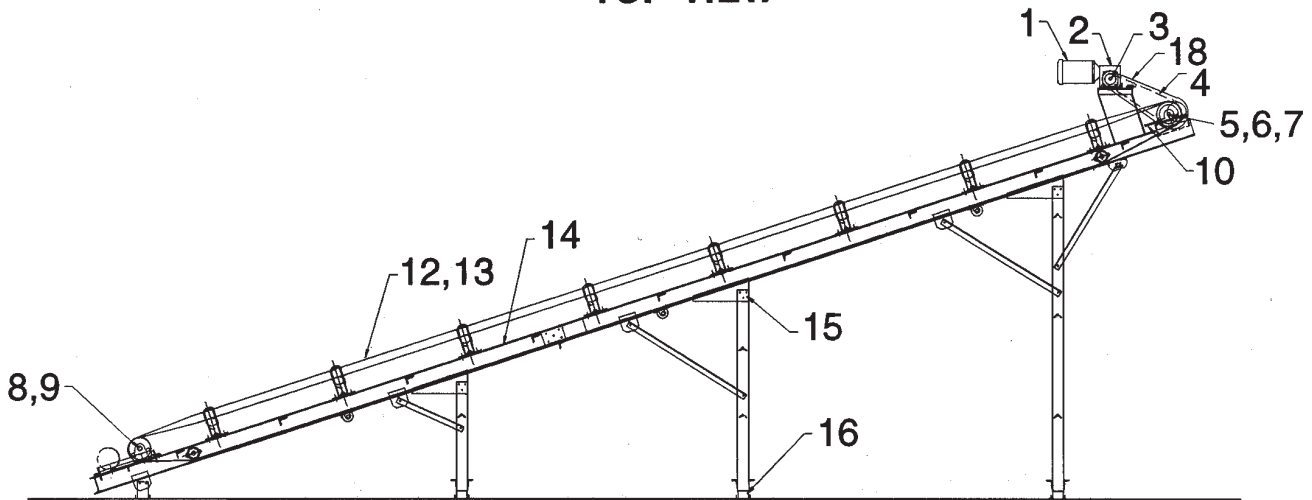

SIDE VIEW

Parts List & Spare Parts

Reference No.	Quantity	Description
1	1	Motor
2	1	Reducer
3	1	Reducer Sprocket
4	1	Roller Chain
5	1	Conveyor Sprocket
6	1	Drive Roll
7	2	Drive Roll Bearings
8	1	Tail Roll
9	2	Tail Roll Bearings
10	4	Adjusting Set Screws
12	1	Belt
13	1	Lacer
14	-	Conveyor Frame Complete (1'-10' sections)
15	-	Swivel Leg Pads
16	-	Fixed Legs
18	1	Chain Guard

Recommended Spare Parts in Highlighted Print.
 Continuing Engineering Advances may cause changes to information shown.

Power-Pack Conveyor Company

38363 Airport Parkway • Willoughby, OH 44094 • Phone: (440) 975-9955 • Fax: (440) 975-0505

Ask About These Additional Creative Solutions To Material Handling Problems

Power-Pack offers you a broad range of material handling products, accessories and technologies. Each one is designed to meet specific conveying needs while meeting your company's production requirements and long-term operating costs as well.

SlimLine Conveyors

These low profile units are designed for part, slug or scrap removal from under stamping presses or other applications that require a compact and reliable conveyor. They feature a sleek design, rugged construction and a wide selection to choose from.

Universal Conveyors

The common frame design used in all 12 models of belt and roller Universal conveyors provides economy and durability for today – and quick interchangeability to meet new needs in the future. Each model can be selected for light, standard or heavy duty applications.

Welded Construction Conveyors

When specifications call for "one piece formed body and welded construction throughout," Power-Pack welded construction conveyors are the right choice. They are available in light, standard and heavy duty construction. Stainless steel models are also available.

Specific Application And OEM Conveyors

Power-Pack offers a wide selection of pre-engineered bulk material handling, part handling, manufacturing and processing conveyors. Each one, including bucket, magnetic and steel hinge belt types can be modified to meet your specific application needs.

Conveyor Types Available

Horizontal Slider Bed
Horizontal Flanged Belt
Horizontal "V" Tracking
Incline
Cleated Incline
Gravity
Horizontal Belt Over Roller
Belt Driven Live Roller
Zero Pressure
Chain Driven Live Roller
Skewed Chain Driven Live Roller
Wire Mesh Horizontal
Wire Mesh Incline
Wire Mesh Cleated Incline
Wire Mesh "L" Style
Wire Mesh "Z" Style
Floor To Floor
Cleated Incline With Nose Over
Table Top Horizontal
Table Top Curve
Die
SlimLine Horizontal
SlimLine Incline
SlimLine Cleated Incline
Steel Hinge Belt Conveyor
Steel Hinge Belt Incline
Steel Hinge Cleated Incline
Steel Hinge "L" Style
Steel Hinge "Z" Style
Self-Cleaning Horizontal
Self-Cleaning Incline
Self-Cleaning Cleated Incline
Flanged Trough Horizontal
Flanged Trough Cleated Incline
Corrugated Horizontal
Corrugated Incline
Corrugated Cleated Incline
Corrugated "L" Style
Corrugated "S" Style
Troughing Idler Horizontal
Troughing Idler Incline
Troughing Cleated Incline
Magnetic Horizontal
Magnetic Incline
Magnetic Cleated Incline
Magnetic Incline W/Nose Over
Magnetic Vertical
Drag Chain Horizontal
Drag Chain Incline
Drag Chain "L" Style
Roller Chain Horizontal
Slat Horizontal
Bucket Elevator
Belt Curves
Wash Conveyor
Roller Flight

Conveyor Components

If your company is looking to build its own conveyors – these pre-engineered modules can help reduce engineering and assembly time. Included are: Power-Pack's patented drive and take-up pulley assemblies, motor packages, leg supports, frames, belts, rollers and more.

Trailer Mounted Sequencing Conveyors

These unique mobile conveyors are specially designed to provide fast plant-to-plant loading of components for just-in-time delivery to line set.

Custom Conveyors

Need a special conveyor design for an in-plant or OEM application? Power-Pack's 60-plus years of material handling, manufacturing and processing experience is at your disposal to design and manufacture a cost-effective solution.

Systems – Synchronized, High Throughput and Storage & Retrieval

Power-Pack systems engineers specialize in creating advanced systems to reduce manufacturing and inventory costs. Innovative systems which can help your company rapidly meet new market demands or competitive pressures.

Preview The Newest Innovations

To keep your engineering staff abreast of the latest material handling technology, ask for our latest video tape titled: "Advanced Handling Systems."



Power-Pack Conveyor Company

38363 Airport Parkway • Willoughby, OH 44094 • Phone: (440) 975-9955 • Fax: (440) 975-0505



**Quality Products,
Quality Service,
Innovative Design:**

The Power-Pack Difference